

SINCE 1970

# Repar2

MACHINE GUARDS

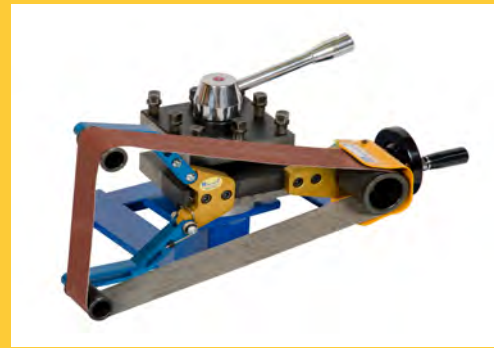

## SPIDER 50 - SPIDER 75 SAFETY BELT SANDER FOR LATHES

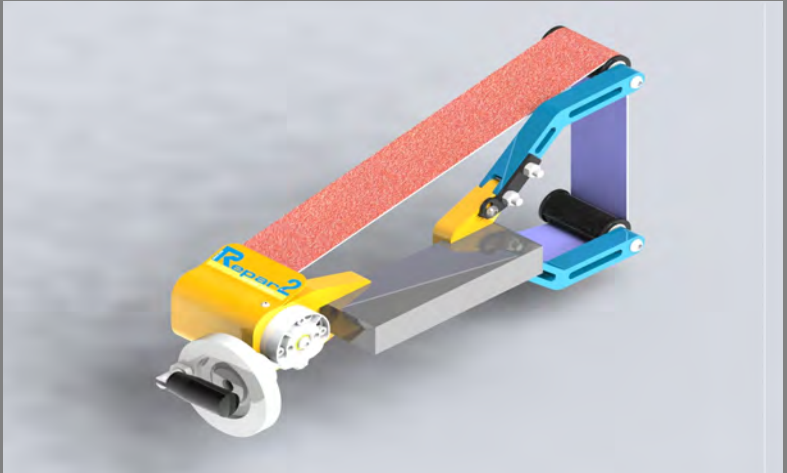
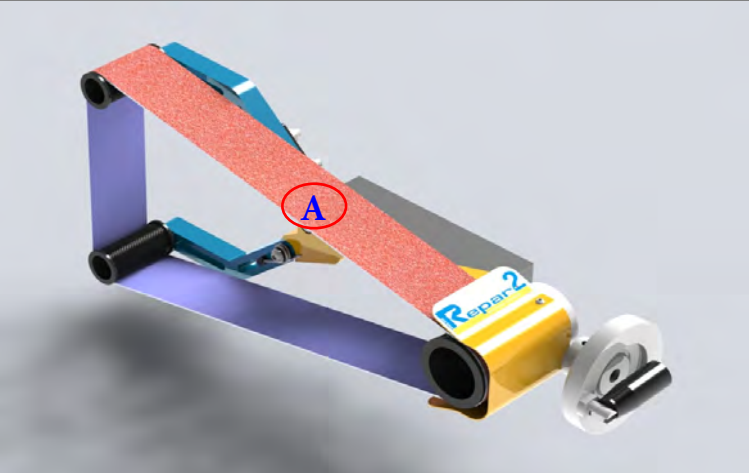
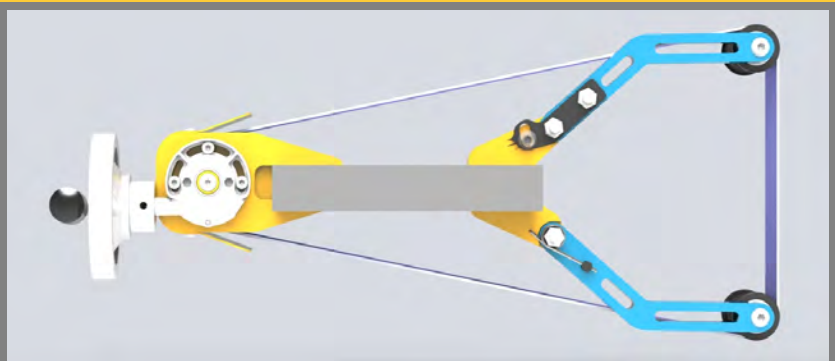
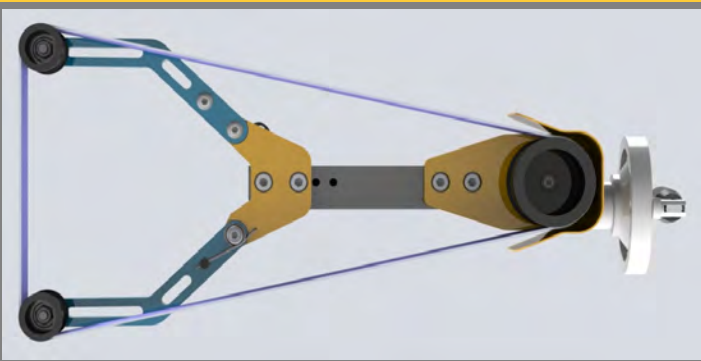

An interesting tool for sanding and finishing parts easily and safely on conventional lathes. Conceived in accordance with ISO23125 Standards 6.2.1 (no use of hands during working operations).  
 No more need to make by hand dangerous sanding operations with risk of serious accidents.  
 Simple fitting of the tool on the lathe turret body.  
 Easy sanding of bars of different diameters and shapes owing to the tool conception and the tensions springs. The sanding belt is rotated easily by means of knurled cylinders in order to guarantee the best working conditions.

**Available in two sizes:**  
 SPIDER 50 - A = 900x50mm Max. Diam. 150mm  
 SPIDER 75 - A = 1100x75mm Max. Diam. 250mm  
 Supplied with 3 standard sand belts  
 (roughness 80 - 120 - 220)

Uno strumento interessante per levigare e rifinire le parti in modo facile e sicuro su torni convenzionali.  
 Concepito in conformità alle norme ISO23125 6.2.1 (nessun uso delle mani durante le operazioni di lavoro).  
 Non è più necessario eseguire manualmente operazioni di levigatura pericolose con rischio di incidenti gravi.  
 Montaggio semplice dell'attrezzo sul corpo della torretta del tornio.  
 Facile carteggiatura di barre di diversi diametri e forme grazie alla concezione dell'utensile e alle molle di tensione. Il nastro levigatore viene ruotato facilmente mediante cilindri zigrinati per garantire le migliori condizioni di lavoro.

**Available in two sizes:**  
 SPIDER 50 - A = 900x50mm Max. Diam.150mm  
 SPIDER 75 - A = 1100x75mm Max. Diam.250mm  
 Supplied with 3 standard sand belts  
 (roughness 80 - 120 - 220)

[www.repar2.com](http://www.repar2.com)

Repar2

Via Ambrogio Colombo, 176 21055 Gorla Minore (VA) Italy  
 Tel. +39 0331 465727 Fax: +39 0331 465728 e-mail: [info@repar2.com](mailto:info@repar2.com)  
 Export Dept: +39 02 33103673 e-mail: [info@eig-group.it](mailto:info@eig-group.it)

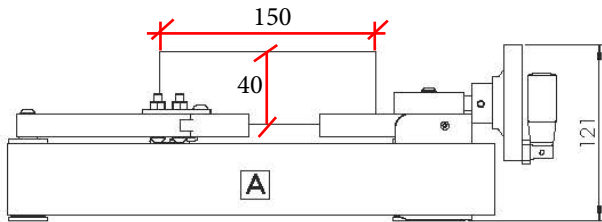
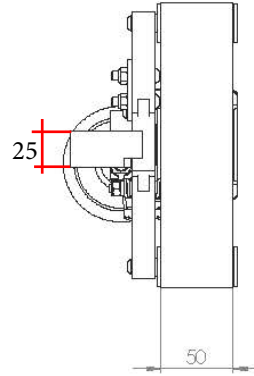
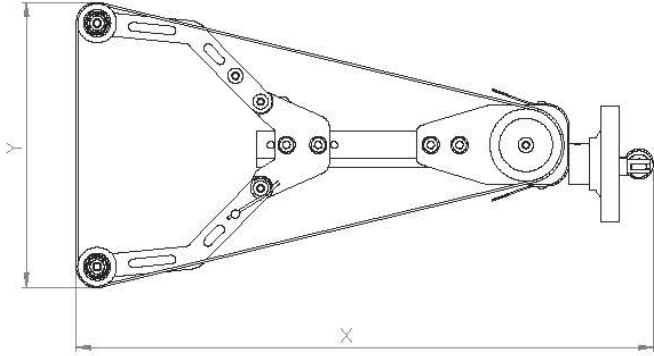

### SPIDER 50

	MIN OPENING	MID OPENING	MAX OPENING
X [mm]	417	400	381
Y [mm]	171	197	227

BELT [A] :  
LENGTH: 900 mm  
WIDTH: 50 mm



**robust**  
Stärke



**stable**  
Stabilität



**ergonomic**  
Ergonomie



**long lasting**  
Dauerhaftigkeit

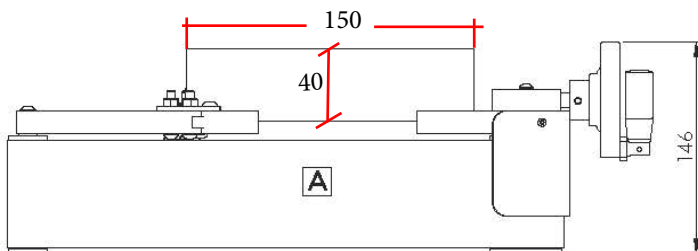
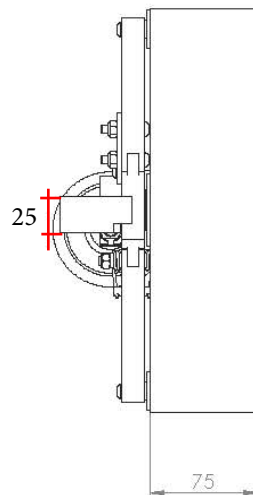
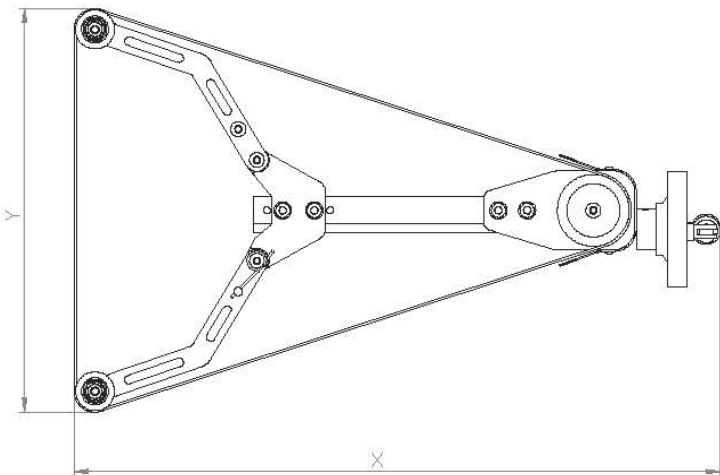

### SPIDER 75

	MIN OPENING	MID OPENING	MAX OPENING
X [mm]	472	450	408
Y [mm]	246	280	336

BELT [A] :  
LENGTH: 1100 mm  
WIDTH: 75 mm